

epic



Contents

1 INTRODUCTION	6
2 INDICATIONS FOR USE.....	7
3 CONTRAINDICATIONS, WARNINGS, AND PRECAUTIONS	8
3.1 Contraindications.....	8
3.2 Warnings and Precautions	8
Prescription Statement	8
Training.....	8
Eyewear.....	8
Anesthesia	8
Adjacent Structures	9
Suction.....	9
Plume Removal	9
Treatment, Technique and Settings	9
Clinical Environment	9
4 SPECIFICATIONS.....	10
4.1 General	10
4.2 Electrical	10
4.3 Laser.	10
4.4 Other Light Sources	10
5 EQUIPMENT DESCRIPTION	11
5.1 System Components.....	11
5.2 General	12
Base Console.....	13
Control Button.	13
Fiber Delivery System	13
Surgical Handpiece	13
Whitening Handpiece (optional)	13
Deep Tissue Handpiece (optional).	14
Wireless Footswitch	14
6 SAFETY WITH THE EPIC 10	15
6.1 Safety Instructions.....	15
6.2 Safety Classification.	16
6.3 Safety Features.....	17

Contents

Energy Monitor	17
System Monitor	17
Power Switch.....	17
Access Key Code.	17
Control Button	17
Wireless Footswitch.....	18
Remote Interlock	18
Emergency Stop.....	18
Functional Display	18
7 INSTALLATION AND SETUP	19
7.1 System Setup	19
Facility Requirements.	19
7.2 Connecting the Fiber Optic Cable	19
7.3 Surgical Handpiece Assembly	20
7.4 Single-Use Tips.....	21
7.5 Connecting the Whitening Handpiece (Optional Accessory)	23
7.6 Connecting the Deep-Tissue Handpiece (Optional Accessory)	23
7.7 Operation-Turn on the Epic 10	25
7.8 Home Screen	25
7.9 Settings Screen.....	26
7.10 Pairing the Footswitch to the Laser Console	26
7.11 Control Button.....	27
7.12 Entering Ready or Standby Modes.....	28
7.13 Ready Mode	28
7.14 Wireless Footswitch	28
7.15 Peak Power Display	29
7.16 Pulse Mode Selection.....	29
7.17 Using the Epic 10 Touch Screen Display	30
7.18 Procedures Button.....	31
7.19 Turn the Laser Console Off	31
8 CLINICAL APPLICATIONS	32
8.1 Overview	32
8.2 Soft-Tissue Surgery and Other Dental Use	32
Tip Initiation: Parameters and Method (Not Required if using Pre-Initiated Tips)	32
Pre-Programmed Settings for Dental Procedures	33
8.3 Table of Pre-Programmed Surgical Settings.....	34
8.4 Teeth Whitening.....	36

Contents

8.5 Pain Therapy	36
Pain TherapyPresetValues.....	37
Pain Therapy-Adverse Effects.....	37
Pain Therapy-Warnings and Precautions	38
Recommended Use.....	39
9 MAINTENANCE	40
9.1 Daily Maintenance	40
9.2 Cleaning and Sterilization Procedures	40
Step 1- Cleaning Process- Surgical Handpiece	40
Step 2- Sterilization Process- Surgical Handpiece	41
Step 3- Disinfecting the Fiber Optic Cable	42
Disinfecting the Whitening Handpiece.....	42
Disinfecting the Deep Tissue Handpiece	42
9.3 Fiber Optic Lens Inspection and Cleaning	43
Lens Inspection Procedure.....	43
Cleaning the Lens	43
9.4 Installing/ReplacingtheConsoleBatterypack.....	44
9.5 Changing the WirelessFootswitch Batteries	45
9.6 Transportation	46
9.7 Storage.....	46
10 CALIBRATION	47
11 SOFTWARE SPECIFICATION.....	47
12 TROUBLESHOOTING	48
APPENDIX A- TIP GUIDE.....	50
APPENDIX B- ACCESSORIES.....	51
APPENDIX C- LABELING	52
APPENDIX D- SAFETY PRECAUTIONS FOR LITHIUM-ION BATTERY PACKS.....	56
APPENDIX E- ELECTROMAGNETIC COMPATIBILITY	58
APPENDIX F- WIRELESS EQUIPMENT COMPLIANCE STATEMENT	62

1 Introduction

The EPIC™ 10 diode laser system is a surgical and therapeutic device at the cutting edge of technology, designed for a wide variety of oral soft tissue procedures and dental whitening, as well as for use in providing temporary relief of minor pain.

The EPIC 10 utilizes a solid state diode as a semiconductor source for invisible infrared radiation. The energy is delivered to the treatment site via a flexible fiber connected at one end to the laser source and the other end to the Handpiece. Various types of single use, disposable tips are designed and optimized for different applications. The device is activated by means of a wireless footswitch.

This is a prescription device that is indicated for professional use only by licensed medical and dental practitioners. The use of this device requires proper clinical and technical training. This manual provides instructions for those professionals that have completed the appropriate training.

When used and maintained properly, the EPIC 10 will prove a valuable addition to your practice. Please contact BIOLASE Customer Service at **1-800-321-6717** in the U.S. for any service needs. If you are located outside the USA, please contact your BIOLASE-authorized distributor.



2 Indications for Use

Use of the Epic 10 device may be appropriate for incision, excision, vaporization, ablation and coagulation of oral soft-tissues including marginal and inter-dental gingival and epithelial lining of free gingiva and the following specifications:

- Excisional and incisional biopsies
- Exposure of unerupted teeth
- Fibroma removal
- Frenectomy
- Frenotomy
- Gingival troughing for crown impressions
- Gingivectomy
- Gingivoplasty
- Gingival incision and excision
- Hemostasis and coagulation
- Implant recovery
- Incision and drainage of abscess
- Leukoplakia
- Operculectomy
- Oral papillectomies
- Pulpotomy
- Pulpotomy as an adjunct to root canal therapy
- Reduction of gingival hypertrophy
- Soft-tissue crown lengthening
- Treatment of canker sores, herpetic and aphthous ulcers of the oral mucosa
- Vestibuloplasty
- Tissue retraction for impression
- Laser soft-tissue curettage
- Laser removal of diseased, infected, inflamed and necrosed soft-tissue within the periodontal pocket
- Sulcular debridement (removal of diseased, infected, inflamed and necrosed soft-tissue in the periodontal pocket to improve clinical indices including gingival index, gingival bleeding index, probe depth, attachment loss and tooth mobility.)
- Light activation for bleaching materials for teeth whitening
- Laser-assisted whitening/bleaching of teeth
- Topical heating for the purpose of elevating tissue temperature for a temporary relief of minor muscle and joint pain and stiffness, minor arthritis pain, or muscle spasm, minor sprains and strains, and minor muscular back pain; the temporary increase in local blood circulation; the temporary relaxation of muscle.

3 Contraindications, Warnings, and Precautions

3.1 CONTRAINDICATIONS

All clinical procedures performed with Epic 10 must be subjected to the same clinical judgment and care used with traditional techniques. Patient risk must always be considered and fully understood before clinical treatment. The clinician must completely understand the patient's medical history prior to treatment and exercise caution for general medical conditions that might contraindicate a local procedure; such conditions may include, but are not limited to, allergy to local or topical anesthetics, heart disease (including pacemakers and implantable defibrillators), lung disease, bleeding disorders, sleep apnea, an immune system deficiency, or any medical conditions or medications that may contraindicate the use of certain light/laser-type sources associated with this device, including general neurovascular conditions which can reduce a patient's pain sensitivity while undergoing pain therapy procedures (e.g., patients with neurodegeneration associated with Type II diabetes). Medical clearance from the patient's physician is advisable when doubt exists regarding treatment.

3.2 WARNINGS AND PRECAUTIONS

PRESCRIPTION STATEMENT

U.S. Federal Law restricts this device to sale by or on the order of a dentist or other licensed dental practitioner.

TRAINING

Only licensed professionals who have reviewed and understood this user manual should use this device. BIOLASE assumes no responsibility for parameters, techniques, methods, or results. Physicians must use their own clinical judgment and professional knowledge to determine all aspects of treatment, including technique, power settings, pulse interval, duration, etc.

EYEWEAR

Doctor, patient, assistant, and all others inside or entering the operatory must wear appropriate laser protective eyewear suitable for the 940 nm \pm 10 nm wavelength, OD4 (DIR LB4) or greater, whenever the laser is in use. Prior to use, inspect eyewear for pitting and/or cracking. **Replace if damaged; do not use.**



CAUTION: The specifications for the protective eyewear provided with the Epic 10 laser system are marked on the side of the glasses. **Always check the eyewear specifications marked on the glasses to ensure they offer the required protection for the specific laser wavelength.**

For additional information, refer to the instructions for use provided with the glasses.

ANESTHESIA

In soft-tissue cases anesthesia may not be required, but patients should be closely monitored for signs of pain or discomfort at all times. If such signs are noted, adjust settings, apply anesthesia, or cease treatment if required.

3 Contraindications, Warnings, and Precautions

ADJACENT STRUCTURES

Epic 10 is designed to remove soft-tissues. Therefore, always be aware of adjacent structures and substructures during use. Be extremely careful not to inadvertently penetrate or ablate underlying or adjacent tissues. Do not direct energy toward hard-tissue such as tooth or bone. Do not direct energy towards amalgam, gold or other metallic surfaces. Do not direct energy towards cements or other filling materials. Exercise extreme caution when using this device in areas such as pockets, cavities or channels such as third molar sockets, where critical structures (i.e. nerves, vessels) could be damaged. Do not proceed with using the laser if visibility is limited in these areas.

SUCTION

Use high-speed suction as required to maintain a clear field of vision during treatment. Do not fire the laser if you cannot clearly see the treatment site.

PLUME REMOVAL



CAUTION: Laser plume may contain viable tissue particulates.

Special care must be taken to prevent infection from the laser plume generated by vaporization of virally or bacterially infected tissue. Ensure that appropriate protective equipment, including high-speed suction to remove the plume, appropriately filtered masks, and other protective equipment is used at all times during the laser procedure.

TREATMENT, TECHNIQUE, AND SETTINGS

Use your clinical judgment to determine all aspects of treatment including, but not limited to, the laser treatment protocol, technique, power settings, pulse duration and interval settings, mode of operation, as well as the accessories utilized (e.g. tip type) and other procedural requirements. Closely observe and monitor clinical effects and use your judgment to determine the clinical parameters and approach for the treatment. Make appropriate power, pulse length, and interval adjustments to compensate for varying tissue compositions, density, and thickness. Always start treatment at the lowest power setting for the specific indication and increase as required. BIOLASE assumes no responsibility for parameters, techniques, methods or results.

CLINICAL ENVIRONMENT

Only use this device in clinical environments that observe proper standard aseptic techniques with all oral procedures.

4 Specifications

4.1 GENERAL

- Dimension (W x L x H) 5.7 in x 6.5 in. x 4.4 in (14.5 cm x 11.2 cm x 16.5 cm)
- Weight 2.5 lbs / 1kg

4.2 ELECTRICAL

- Operating voltage 100V - 240V ~ at 1.5A
- Frequency 50 / 60 Hz
- External Fuses None
- Main control Main Power Switch (ON/OFF Control Button)
- Remote Interruption Remote interlock
- Disable Control Emergency Stop Button
- Battery Lithium Ion Rechargeable, 14.6, 2.75Ah
- DC Power Supply Module 12V DC, 5A

4.3 LASER

- Laser Classification IV (4)
- Medium InGaAs Semi-conductor diode
- Wavelength 940 ± 10nm
- Max Power Output 10W
- Power Accuracy ± 20%
- Power Modes Continuous, Pulse Modulation
- Fiber Tips Diameter 200µm, 300µm, 400µm
- Pulse Duration 0.01ms – 20ms
- Pulse Interval 0.04ms – 20ms
- Pulse Repetition Rate Up to 20kHz (for reference)
- Spot Size
 - > Surgical Handpiece 400µm (maximum in contact mode)
 - > Deep Tissue Handpiece 30mm diameter = 7.1cm² area
 - > Whitening Handpiece 35mm x 8mm = 2.8cm²
- NOHD (Nominal Ocular Hazard Distance) 2.71 meters
- MPE (Maximum Permissible Exposure) 30W/m²
- Beam Divergence 7 - 22° per side angle
- Standard Fiber Cable Length 5 feet (1.5 meters)

4.4 OTHER LIGHT SOURCES

- Aiming Beam Laser diode, max 1 mW, 625 nm – 670 nm, Class 2

5 Equipment Description

5.1 SYSTEM COMPONENTS

The Epic 10 laser system includes the following:

1. Laser Console
2. Peel-off Screen Protectors (qty. 30)
3. Fiber Optic Cable (Installed)
4. Assorted Surgical Tips
5. Surgical Handpiece (qty. 2)
6. Laser Protective Eyewear (qty. 3)
7. DC Power Supply Module
8. Power Cord (one (1) U.S, one (1) International)
9. Welcome Kit (Includes User Manual and Quick Setup Guide)
10. Laser Warning Sign
11. Tip Initiation Kit
12. Remote Interlock Cable
13. Footswitch
14. Philips-Head Screwdriver (for installing Footswitch batteries)
15. AAA Batteries (qty. 2)

Optional Accessories:

- Whitening Handpiece
- Deep Tissue Handpiece



WARNING: No modification of this equipment is allowed.

5 Equipment Description

5.2 GENERAL

The Epic 10 system consists of three components:



Figures 4.1

5 Equipment Description

BASE CONSOLE

The base console is portable, contains the diode laser and all the elements which power the laser, and has a touchscreen which allows the user to navigate from screen to screen, select procedures, enter and/or change settings, etc. (Figure 4.1).

CONTROL BUTTON:

Activates the controls and console display; places the laser into **Standby, Ready, or Sleep** mode.

LED Indicators: Amber = Standby mode

Green = Ready mode

Blinking green = Laser is firing

Blinking blue = Pairing active

FIBER DELIVERY SYSTEM

The fiber delivery system (Figure 4.2) consists of the Fiber Optic Cable, the reusable surgical Handpiece, and the fiber Tips, and transmits laser radiation from the laser console through the Handpiece and fiber Tips to the target tissue. The laser ships from the factory with the Fiber Optic Cable already attached to the base console.

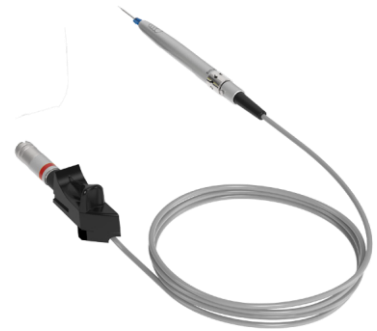

Figure 4.2

SURGICAL HANDPIECE

The Surgical Handpiece (Figure 4.3) is a re-usable Handpiece. It is a conduit for delivering the optical energy produced by the laser to the treatment site and must be cleaned and sterilized between patients to avoid cross-contamination (See Section 9).



Figure 4.3

WHITENING HANDPIECE (OPTIONAL)

The Whitening Handpiece is a re-usable Handpiece used in conjunction with the Biolase LaserWhite 20 Whitening Gel for teeth whitening; packaging includes disposable non-sterile shields for single-patient use (Figure 4.4) which are installed over the Handpiece lens prior to each use.



Figure 4.4

5 Equipment Description

DEEP TISSUE HANDPIECE (OPTIONAL)

The Deep Tissue Handpiece is a re-usable Handpiece used for pain therapy (Figure 4.5). The Handpiece is equipped with disposable non-sterile shields for single patient use. The shields are applied to the spacer and discarded after one-time use.



Figure 4.5

WIRELESS FOOTSWITCH

The Epic 10 laser will only emit laser energy when the user presses down on the Footswitch while the laser is in **Ready** mode. It is designed to work using wireless technology and is powered by two AAA batteries which are installed prior to shipment from the factory; it ships already paired to the base console.

The Footswitch is protected by a metal cover. To access, first press down on the cover to unlatch it, then press the Footswitch to fire the laser (Figure 4.6).



Figure 4.6

6 Safety with the Epic 10

Failure to comply with the precautions and warnings described in this user manual may lead to exposure to dangerous optical radiation sources. Please comply with all safety instructions and warnings.



WARNING: Use of controls or adjustments or performance of procedures other than those specified in this User Manual may result in hazardous radiation exposure.

6.1 SAFETY INSTRUCTIONS

Follow these safety instructions before and during treatments:

- When the laser is in use, all operatory entrances must be marked with an appropriate warning sign (included - see Appendix B).
- **Do not** operate in the presence of explosive or flammable materials. Flammable anesthetics or oxidizing gases such as nitrous oxide (N₂O) and oxygen (O₂) should be avoided. Solvents of adhesives and flammable solutions used for cleaning and disinfecting should be allowed to evaporate before the laser is used. Attention should also be drawn to the danger of ignition of endogenous gases.
- **All persons present in the operatory must wear laser protective eyewear.** Always ensure that the laser protective eyewear is appropriate for the laser wavelength; refer to the markings on the eyewear itself for the specifications of the protection provided.
- Prior to use inspect the eyewear for pitting and/or cracking; do not use if damaged; for replacement or additional laser protective eyewear, please contact BIOLASE.
- **Do not** look directly into the beam or at specular reflections.
- **Never** direct or point the beam at a person's eyes.
- Always place the system into **Standby** mode (by pressing the control button while in **Ready** mode) before exchanging Handpieces or disposable Tips.
- Always ensure that the proper laser parameters are set before the Epic 10 laser is used in a clinical procedure.
- Toggle the ON/OFF switch (located on the rear of the console) to the OFF (O) position before leaving the unit unattended.
- **Do not** use the Epic 10 if the Fiber Optic Cable is damaged or broken.
- **Do not** use the laser if there's a suspicion it is not functioning properly or other than described in this User Manual.

6 Safety with the Epic 10



LASER WARNING: DO NOT open the console housing at any time. Danger from optical radiation may exist.

DO NOT aim the laser at metallic or reflective surfaces, such as surgical instruments or dental mirrors. If aimed directly at these surfaces the laser beam will reflect creating a potential hazard.



CAUTION: DO NOT position this equipment so that it is difficult to pull the plug from the power source.



CAUTION: To avoid the risk of electric shock, this equipment must only be connected to a supply mains with protective earth.



CAUTION: High temperatures produced in the normal use of this laser equipment may ignite some materials (e.g., cotton wool when saturated with oxygen); solvents or adhesives and flammable solutions used for cleaning and disinfecting should be allowed to evaporate before the laser equipment is used.



CAUTION: Be aware that the metal/plastic cannula on the Tips may become hot during use. Avoid contact of the cannula with any tissue.



CAUTION: This laser system has been designed and tested to meet the requirements of electromagnetic, electrostatic, and radio frequency interference standards. However, the possibility of electromagnetic or other interference may still exist. Relocating the device may help to eliminate the interference.

6.2 SAFETY CLASSIFICATION

The following safety classifications are applicable to the device:

- Laser radiation – Class 4
- Aiming Beam – Class 2
- Type of protections against electrical shock – Class 1
- Degree of protection against electrical shock – Type B applied part
- Not protected against water ingress – Ordinary equipment
- Not suitable for use in presence of flammable anesthetic mixture
- Operation mode – Continuous wave and pulse mode
- Wireless Footswitch – IPX6

6 Safety with the Epic 10

6.3 SAFETY FEATURES

ENERGY MONITOR

The energy monitor measures and verifies power output. Power deviations of more than $\pm 20\%$ from the selected value will cause the display to show the error message: "LASER CURRENT HIGH/LOW".

The laser console will not operate until the system first clears the error and then goes into **Ready** mode. If the error message persists, please contact BIOLASE Service at **1-800-321-6717** or your BIOLASE-authorized service representative.

SYSTEM MONITOR

The system monitors the emergency stop switch, remote key, wireless Footswitch connection, and output power. An error in any one of these will stop the system. The text display will indicate the type of error. Operation cannot resume until the error is cleared.

POWER SWITCH

The laser console can be switched ON (I) or OFF (O) using the power switch on the back of the console. Turn the power switch OFF (O) only when the system will not be in use for a long period of time.

ACCESS KEY CODE

The Access Key Code (**888**) prevents unauthorized use of the system. It is activated every time the system is turned ON with the power switch.

Placing the laser in **Sleep** mode by pressing and holding the Control button on the front panel of the console does not re-set the access key code.

CONTROL BUTTON

Once the power switch is set to the ON (I) position, enter the access key code. After setting the desired parameters for a procedure, press the CONTROL button on the control panel to enter into **Ready** mode. The aiming beam will illuminate to indicate that the system is ready for use.



Figure 6.1: Power Switch, DC Power Input, Remote Interlock



Figure 6.2: DC Power Supply Module

6 Safety with the Epic 10

WIRELESS FOOTSWITCH

The Epic 10 will not emit laser energy until the user presses down on the Footswitch while the laser is in **Ready** mode. The Footswitch is designed to work using wireless technology and is paired to the laser console at the factory.

REMOTE INTERLOCK

This feature allows the laser to be connected to a remote sensor which prevents it from firing when the sensor is triggered. To install the remote interlock, insert the plug **(a)** at the end of the connector (Figure 6.4) into the rear of the laser console and attach the two wires **(b)** at the other end to a door switch; the laser will stop immediately when the connection to the door switch is deactivated, i.e., when the door is opened.

EMERGENCY STOP

Press the red emergency laser stop button to instantly turn off the laser console. The message “Emergency Switch Error” will appear on the console display and the amber LED will begin flashing. To clear the error, press the emergency laser stop button again; in 2 to 5 seconds the amber LED will stop flashing and the system will automatically go into **Standby** mode.

FUNCTIONAL DISPLAY

The system color display with touch screen and LED indicators on the control panel shows the functional conditions of the system.



Figure 6.3: Wireless Footswitch

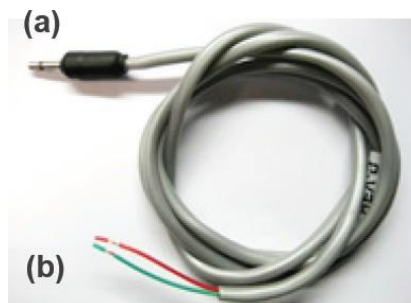

Figure 6.4: Remote Interlock Connector



Figure 6.5: Emergency Laser Stop



CAUTION: Use only the DC Power Supply Module supplied with the Epic 10 laser system. (BIOLASE P/N 2400075)

7 Installation and Set-Up

7.1 SYSTEM SETUP



NOTE: The laser ships with the lithium ion battery pack already installed.

FACILITY REQUIREMENTS:

Electrical Supply: 100V - 240V ~ at 1.5A, 50/60Hz

Environmental: Temperature 15-35 °C (59-95 °F), Humidity 10-90%, non-condensing

- Place the unit in a clean, dry, and well-ventilated area; **do not** cover or block the ventilation channels. These channels provide an air-flow path to cool the unit.
- Verify the power switch is in the OFF (O) position.
- Epic 10 will work using either DC power or its rechargeable battery pack:
 - o DC Power Supply Module: Connect the DC power supply module to the laser console, attach one end of the power cord to the DC power supply module and plug the other end of the power cord into a wall outlet.
 - o Rechargeable Battery: The Epic 10 is shipped with the battery pack already installed; to charge the battery pack, connect the power cord of the DC power supply module to the laser console and plug into a wall outlet. Before first use, fully charge the battery (at least 3 hours). Once the battery is charged, unplug the power cord from the wall outlet and the laser console. The laser console will run on battery power alone. To fully charge the battery, plug the DC power supply module in and then turn the laser console ON (I) at the power switch. The laser console will start to charge and the unit will go into Sleep mode (the screen is dark) after 5 minutes; if the power supply is plugged in but the console is turned OFF (O) at the power switch, the battery will still charge, but at a slower rate.

7.2 CONNECTING THE FIBER OPTIC CABLE

The Epic 10 ships with the Fiber Optic Cable already connected to the laser console.



CAUTION: Do not connect or disconnect the fiber cable while the laser console is turned ON. Only connect or disconnect the fiber when the laser console is turned OFF.

To disconnect the Fiber Optic Cable from the laser console, **make sure the laser console is turned off and the cable is completely unwound from the console base**, grab the Fiber Optic Cable access plug and slowly pull it straight back from the optical access port (Figure 7.1).

To re-install the Fiber Optic Cable, **make sure the laser console is turned off**. The Fiber Optic Cable is attached to the console by inserting the optical access plug (Figure 7.1) into the optical access port (Figure 7.2).

For storage, wind the Fiber Optic Cable in the fiber storage channel around the base of the console in a counterclockwise direction.



Figure 7.1: Optical Access Plug



Figure 7.2: Optical Access Port



CAUTION: Do not bend the Fiber Optic Cable at a sharp angle, as it can break. Make sure it is not caught or pinched between the housing and the fiber optic access plug.

7.3 SURGICAL HANDPIECE ASSEMBLY



CAUTION: The surgical Handpiece is not sterile when shipped and **MUST** be sterilized **prior to initial use, and cleaned and sterilized between patients.**

To connect the Handpiece to the Fiber Optic Cable, push the Handpiece onto the fiber shaft, without twisting, until it clicks into place and is secured (Figures 7.3, 7.4). If no click is audible, disconnect the Handpiece and then re-install it.

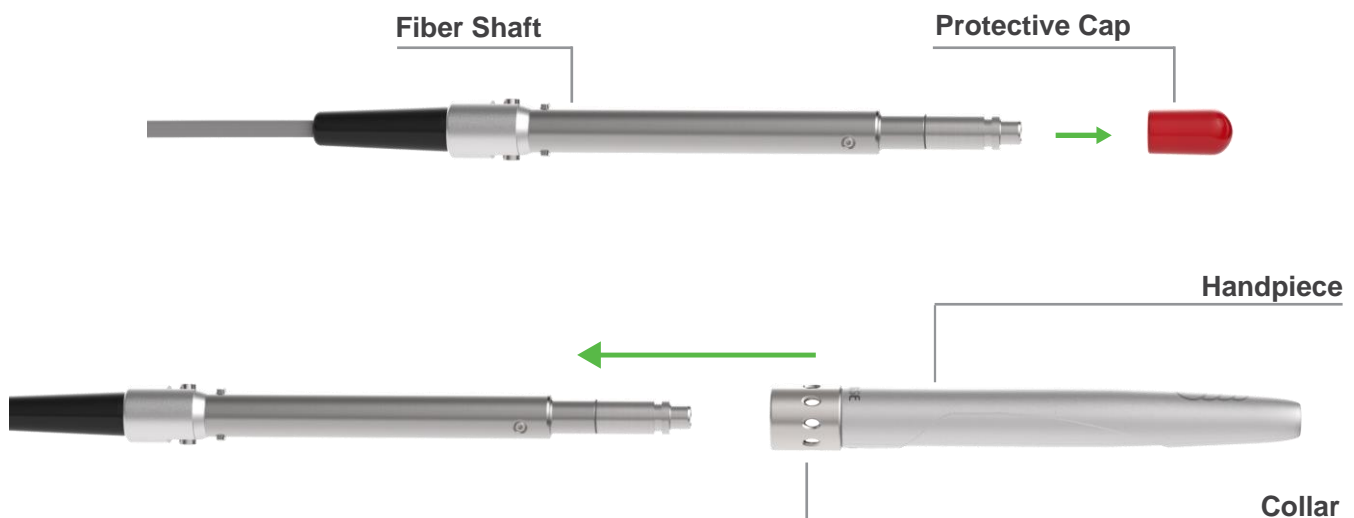

Figure 7.3: Connecting the Handpiece to the Fiber Optic Cable

7 Installation and Set-Up



Figure 7.4: Surgical Handpiece Assembly fully assembled

To disconnect the Handpiece from the Fiber Optic Cable (Figure 7.5):

1. Take the Handpiece body in one hand and the shaft in the other,
2. Pushing the two buttons on the fiber shaft,
3. Gently pull the Handpiece by the collar to separate it from the fiber shaft, without twisting.

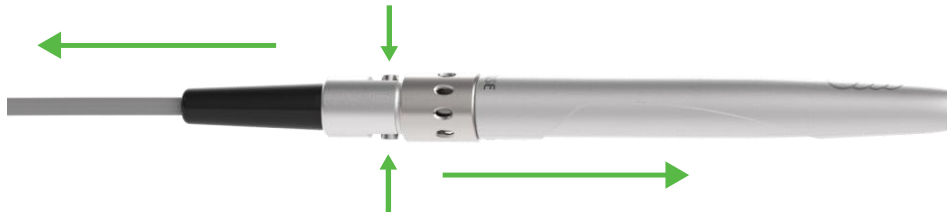

Figure 7.5: Disconnecting the Handpiece from the Fiber Optic Cable

7.4 SINGLE-USE TIPS

The Tips are single-use accessories and are provided in three core diameters: 200 μ m, 300 μ m, and 400 μ m, and in different lengths (see Appendix A).



CAUTION: Tips are single-use only to avoid cross-contamination and are designed to withstand only a single sterilization cycle; they must be disposed of after use in a biohazard medical waste sharps container. Always visually inspect the Tip prior to use to make sure it is free of debris or damage.

To connect the Tip, remove the protective cap from the end of the fiber shaft, connect the Handpiece to the Fiber, then insert the tip firmly into the distal end of the Handpiece as far as it will go and tighten by turning clockwise (Figure 7.6). Bend the metal cannula according the specific procedure requirements (Figure 7.9).

Remove the fiber Tip by twisting the Tip counterclockwise (Figure 7.7).



Figure 7.6: Insert the fiber Tip into the Handpiece (**only when the Handpiece is connected to the fiber**) and twist clockwise until snug



Figure 7.7: Remove the fiber Tip by twisting the Tip counterclockwise



CAUTION: For proper laser operation, do not connect the Tip when the Handpiece is not connected to the fiber.

Correct



Incorrect



Figure 7.8 : Installing the Tip

Correct



Incorrect

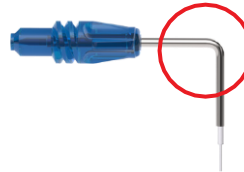

Figure 7.9: Bending the Tip cannula



CAUTION: Be aware that the metal cannula on the Tips may become hot during use. Avoid touching the cannula to any tissue. Should the Tip become excessively hot, make sure it is properly installed (Figure 7.8), or, if the bend radius of the tip is too acute, the fiber tip inside the cannula may be broken. Replace the tip.



CAUTION: When using *uninitiated* tips, if the aiming beam is not present or has a significantly asymmetrical shape, the tip may be broken or damaged; change the tip.

If using a *pre-initiated* tip, the aiming beam may not be visible, or may be fuzzy; this is normal. The tip does not need to be replaced.

The Handpiece is now ready to use. To store the Handpiece, place it in the Handpiece Holder located at the top of the laser console.

Wind any excess Fiber Optic Cable onto the fiber spool counterclockwise around the base of the console.



LASER WARNING: Never operate the laser without a fiber Tip attached to the Handpiece. Never point the laser at a person's eyes. All persons present in the operatory must wear protective eyewear when the laser is in use.

7 Installation and Set-Up

7.5 CONNECTING THE WHITENING HANDPIECE (OPTIONAL ACCESSORY)

The Whitening Handpiece is a reusable accessory and is provided with disposable non-sterile protective shields designed for single patient use. The Handpiece is non-sterile and requires disinfection before and after each patient treatment. **This Handpiece cannot be sterilized in the autoclave.** For instructions on how to clean and disinfect the Handpiece, refer to Section 9.

Always wipe the disposable shield with alcohol prior to use. The disposable shield is for single-use only to avoid cross-contamination. Discard when the treatment session is completed.

To connect the Handpiece to the Fiber Optic Cable, push the Handpiece onto the fiber shaft until it clicks on and is secured.

To disconnect the Handpiece from the Fiber Optic Cable, press and hold both buttons at the base of the fiber shaft and gently pull the Handpiece to separate.



Figure 7.10: Whitening Handpiece and disposable non-sterile shield



Figure 7.11



NOTE: Refer to the individual Instructions for Use included with the Whitening Handpiece packaging for additional details.

7.6 CONNECTING THE DEEP TISSUE HANDPIECE (OPTIONAL ACCESSORY)

The Deep Tissue Handpiece is a reusable accessory and is provided with disposable non-sterile protective shields designed for single patient use. The Handpiece is non-sterile and requires disinfection before and after each patient treatment. **This Handpiece cannot be sterilized in the autoclave, as doing so will damage its internal optics.** For instructions on how to clean and disinfect the Handpiece, refer to Section 9.

Always wipe the disposable shield with alcohol prior to use. These shields are for single-use only to avoid cross-contamination and must be discarded after one-time use.



Figure 7.12 : Deep Tissue Handpiece

- To connect the Handpiece to the Fiber Optic Cable, slide the Handpiece over the fiber shaft until it clicks on and is secured; if no click is audible, disconnect the Handpiece and then re-install it.
- Remove the yellow cap dust cover (Figure 7.13).
- Set the spot size to 30mm by loosening the lock ring and sliding the spacer to the 30mm spot size detent location (Figure 7.12); tighten the lock ring to prevent the spacer from moving during treatment.
- Place the disposable protective shield over the adjustable spacer (Figures 7.14, 7.15).

The Handpiece is now ready to use.

To disconnect the Handpiece from the Fiber Optic Cable, press and hold both buttons at the base of the fiber shaft and gently pull the Handpiece to separate.



Figure 7.13



Figure 7.14



Figure 7.15



Figure 7.16



NOTE: Refer to the individual Instructions for Use included with the Deep Tissue Handpiece packaging for additional details.

7.7 OPERATION - TURN ON THE EPIC 10

Operate with the battery, or connect the DC power supply module to the power connector on the laser console and plug the cord into a wall outlet.

Turn the power switch at the rear of the console to the ON (I) position. The “BIOLASE” logo screen will appear. After three (3) seconds the Epic 10 “Welcome” screen will be displayed.

- Enter the three digit access code using the touch screen. The access key code is 888 (if the incorrect code is entered an “X” appears briefly in the window; press the “X” or wait 3 seconds to revert back to the Welcome screen, then re-enter the correct code.
- The system will go to the HOME screen which identifies three Procedure categories to choose from: Soft Tissue, Whitening, Pain Therapy.

7.8 HOME SCREEN

The Home screen offers four operational options:

- Soft-tissue: This selection displays the procedures menu which contains 14 pre-programmed clinical procedures and up to 6 custom pre-sets
- Whitening: This function provides access to the whitening procedure screen which displays the parameters and corresponding mode and Handpiece for the whitening application. The settings are pre-programmed at the factory and cannot be adjusted by the user
- Pain therapy: This option displays the operation screen for pain therapy at settings pre-programmed at the factory.
- Settings icon (bottom center): Accesses the settings screen; allows the user to make changes to several system settings, including language

This screen also displays how much strength is left in the console battery (upper right corner), and whether the wireless connection between the Footswitch and console is at full strength (upper left corner).



Figure 7.17



Figure 7.18

7 Installation and Set-Up

7.9 SETTINGS SCREEN

Pressing the Settings button on the HOME screen accesses the Settings screen; the user may make changes to the following system settings:

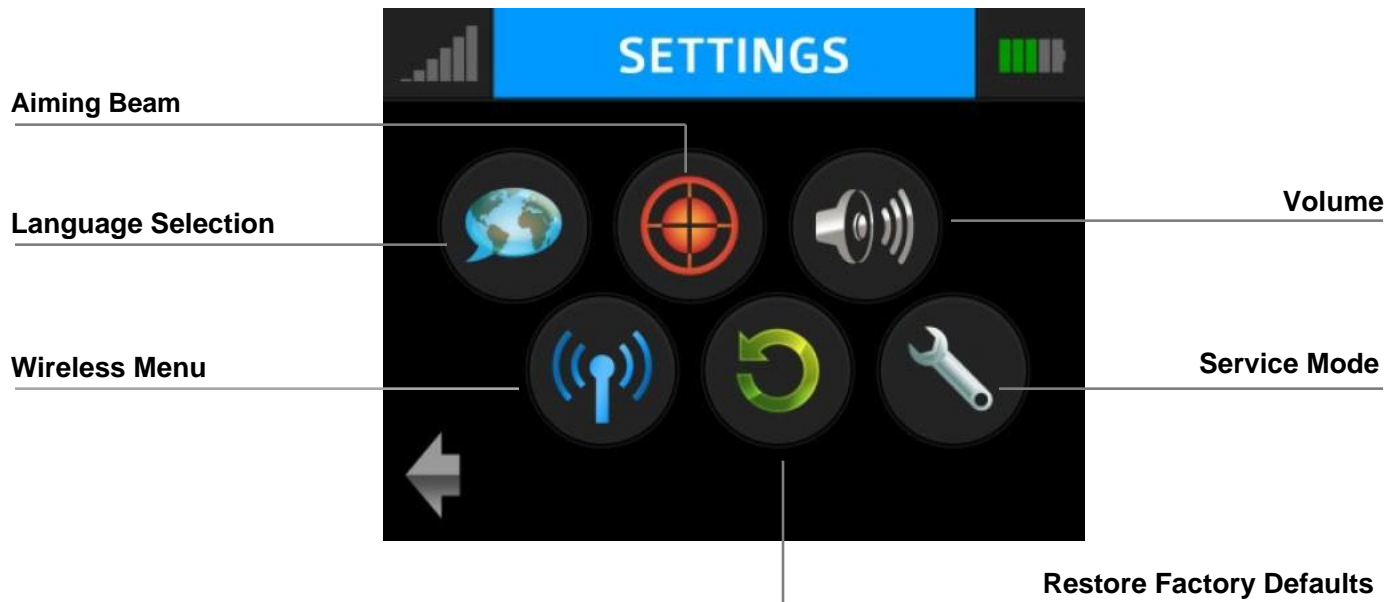

Figure 7.19

7.10 PAIRING THE FOOTSWITCH TO THE LASER CONSOLE

Verify that the Footswitch and laser console are paired; a blue LED indicator light on the laser console will blink when pairing is established. The laser and Footswitch are shipped already paired. However, if pairing is not confirmed, an "x" will appear over the pairing icon located in the upper left hand corner of the touchscreen.



Figure 7.20

To re-establish pairing, take the following steps:

1. Go to the settings menu on the laser console display by pressing the settings icon; select the “Wireless” icon.
2. A screen will appear indicating that pairing of the Footswitch to the laser console has been lost (Figure 7.21); press the green PAIR button.
3. The message that “PAIRING WILL NOW BEGIN” will appear (Figure 7.22); press the green check mark to continue.
4. To complete the pairing process, turn the Footswitch over and press the pairing button for four (4) seconds (Figure 7.23).
5. The wireless screen will appear indicating that pairing was successful and that the Footswitch and laser console are now paired (Figure 7.24). Proceed to step 7.
6. If pairing has not occurred, the wireless screen will appear again indicating that pairing was not successful (Figure 7.25); press the green button to repeat steps 3 and 4.
7. Press the settings button to return to the settings menu; press the arrow on the bottom left of the settings screen to return to the home screen (Figure 7.26).

7.11 CONTROL BUTTON

The CONTROL button on the front of the laser console is a multi-function button. Pressing and holding the CONTROL button for approximately two (2) seconds will allow the transition from Standby or **Ready** mode to Sleep mode. Note that you will not be allowed to go into **Ready** mode unless you have chosen a treatment module on the HOME screen.



Figure 7.21



Figure 7.22



Figure 7.23



Figure 7.24



Figure 7.25

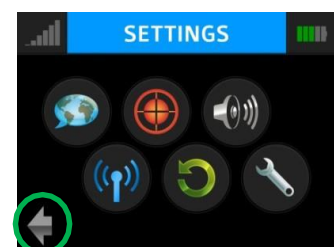

Figure 7.26

7 Installation and Set-Up

7.12 ENTERING READY OR STANDBY MODES

Press and release the Control button to place the laser console into either **Ready** or **Standby** mode (the mode is displayed in the lower right hand corner of the console). The laser console will only emit laser energy when the Footswitch is pressed, and the laser console is set to **Ready** mode. While in **Ready** or **Standby** mode, mode setting and/or power setting values may be changed only when the laser is not firing. If the laser is firing (i.e., the Footswitch is engaged), the ability to change the settings is blocked.

7.13 READY MODE

When entering **Ready** mode, the laser console fan will turn on; pressing the Footswitch will activate the emission of laser radiation. There is a two (2) second delay between switching to **Ready** mode and the ability of the laser console to emit a laser beam.



NOTE: The aiming beam is on only when the laser is in **Ready** mode or when adjusting the brightness of the beam while in Settings mode. If the aiming beam is not visible in either instance, remove the Handpiece and confirm the beam is actually on by shining the end of the Fiber Optic Cable on a plain, non-reflective surface. **DO NOT** look directly at the output end of the Fiber Optic Cable. If the aiming beam is not on, turn off the laser console, then remove and re-install the Fiber Optic Cable assembly. If the aiming beam is still not on, turn off the laser console and call your authorized service representative.

7.14 WIRELESS FOOTSWITCH

The wireless Footswitch is powered by two (2) AAA batteries.

When the wireless Footswitch is pressed in **Ready** mode and the laser fires, a beeping sound indicates that laser energy is present. A green LED will begin flashing and a blue LED will light at the top corners of the laser console, confirming the Footswitch and laser are paired.

In the top left corner of most screens is a signal strength indicator which displays the signal strength between the laser console and the Footswitch (strongest is five (5) bars). Pressing and releasing the Footswitch while in Standby mode will update this indicator. Although the unit will work with a signal level as low as one (1) bar, a weaker signal level will make the connection between the Footswitch and laser console more vulnerable to wireless (RF) interference from other sources, such as cell phones or microwaves. To improve the signal strength, reposition either the Footswitch or the laser console until the signal indicator achieves the strongest possible level for optimal operation.



NOTE: If the Footswitch is pressed while the system is in **Standby** mode, the screen will display **ALERT 2**, indicating the system is not in **Ready** mode. Press the control button to switch to **Ready** mode.

When the Footswitch is not in use, it will go into **Sleep** mode to conserve battery power. It automatically reactivates when pressed.

7.15 PEAK POWER DISPLAY

This number is shown only when the system is in Pulse mode and presents the value of the peak power based on the power setting and Pulse mode.

7.16 PULSE MODE SELECTION

Pulse mode selection graphically indicates whether the system is in Continuous mode or in Pulse mode.

In Continuous mode, laser power is constantly delivered when the laser console is in **Ready** mode and the wireless Footswitch is activated.

In Pulse mode, laser power is delivered in repetitive pulses, controlled by the Pulse Length and Pulse Interval settings. Pressing the Pulse mode button will allow switching between Pulsed and Continuous modes (Figure 7.29).

Mode*	Pulse Duration (on)	Pulse Interval (off)	Duty Cycle (Time On/Time off)
CP0	10 microseconds	40 microseconds	20%
CP1	100 microseconds	200 microseconds	33%
CP2	1 millisecond	1 millisecond	50%
P3	20 milliseconds	20 milliseconds	50%

*CP = Comfort pulse; P3 = Pulsed mode which is the standard for most diode lasers currently available to the dental market

Figure 7.27



NOTE: Operating the laser at a shorter pulse duration typically results in lower tissue temperature.



Figure 7.28

7 Installation and Set-Up

7.17 USING THE EPIC 10 TOUCH SCREEN DISPLAY

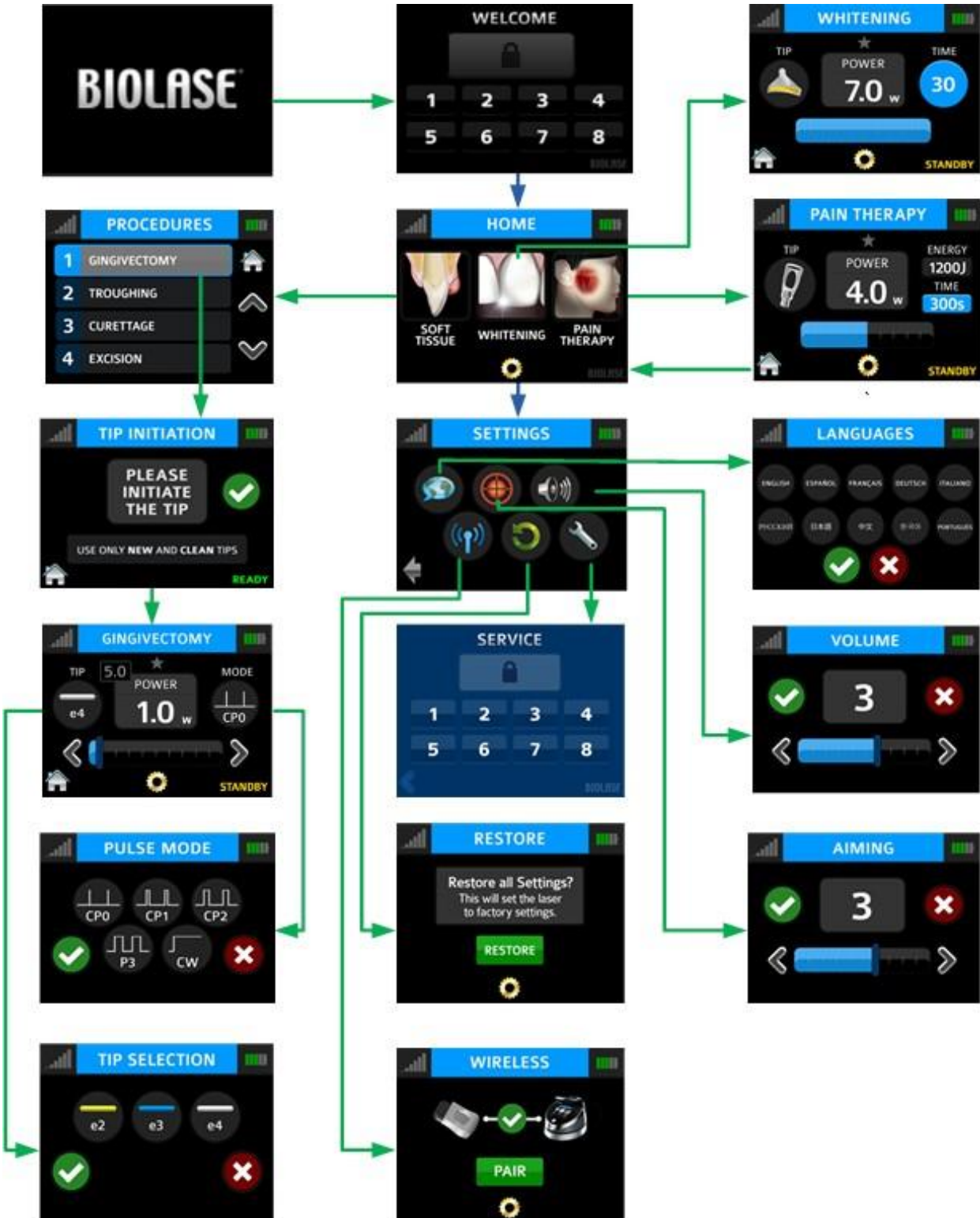

Figure 7.29

7.18 PROCEDURES BUTTON

The Epic 10 has the ability to store up to 20 pre-set procedures; Epic 10 is factory-installed with 14 pre-programmed procedural presets and 6 empty slots for custom pre-sets. All of them can be customized to your preference.

To customize the parameters (e.g., power, pulse duration, interval, etc.) for a particular clinical procedure:

1. Go to the PROCEDURES menu by pressing the soft-tissue icon on the HOME screen; scroll to and select the pre-set you wish to overwrite (Figure 7.30).
2. Press and hold the banner on the selected procedure for two seconds (Figure 7.31). The parameters for that procedure will be changed and saved (the laser console will beep when the adjusted settings are saved).

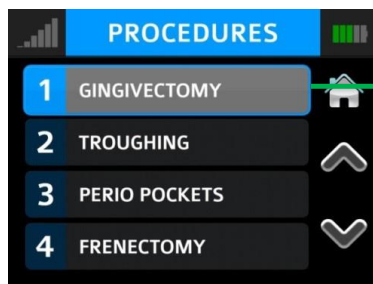

Figure 7.30



Figure 7.31

7.19 TURNING THE LASER CONSOLE OFF

- Wind the Fiber Optic Cable onto the fiber storage channel counterclockwise around the base of the console
- Place the Handpiece onto the Handpiece Holder



CAUTION: Verify that the Fiber Optic Cable tubing assembly is not twisted once the Handpiece is returned to the holder. The fiber may break if it is twisted.

- Press the CONTROL button on the front of the console for more than 2 seconds to turn the console display off
- Press the power switch at the rear of the laser console to the OFF (O) position if the laser system will not be used for an extended period of time

8 Clinical Applications

8.1 OVERVIEW

To efficiently treat tissues, it is imperative to understand the nature of the Epic 10 device. Please review this section carefully, practice on model tissues, and attend a diode laser training session before using this device in a clinical situation.

8.2 SOFT TISSUE SURGERY AND OTHER DENTAL USE

TIP INITIATION: PARAMETERS AND METHOD (NOT REQUIRED IF USING PRE-INITIATED TIPS)

Most soft-tissue surgical procedures require initiation of the fiber Tip. **The TIP INITIATION screen will appear (in Ready mode) if Tip initiation is recommended** and the system will automatically go to the settings shown in Section 8.3 based on the Tip used; while in the TIP INITIATION screen, initiate the Tip by following the steps outlined below.

Tip Diameter (μm)	(Preset) Power (W)	Mode
400	1.4	CW
300	1.4	CW
200	Tip initiation not required when used for recommended procedures	

Figure 8.1

- Touch the Tip to the surface of the initiation block, without activating the laser (don't press down on the Footswitch (Figure 8.2)
- Press the Footswitch to activate the laser, allowing the tip to sink into the block. Pull the Tip out when the metal cannula touches the block, still firing until just before the Tip is out of the block (Figure 8.3)
- Press the Footswitch to activate the laser into the air once; a white flash will be visible or the Tip will glow (Figure 8.4)
- Repeat initiation process as needed to ensure the Tip is initiated

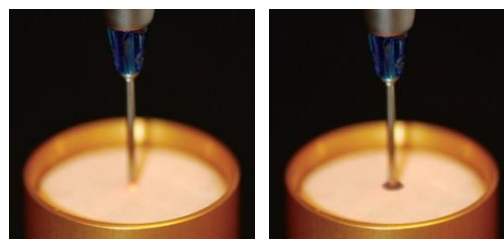

Figure 8.2

Figure 8.3



Figure 8.4

8 Clinical Applications

After Tip initiation is completed, press the check mark to access the screen for the selected procedure.

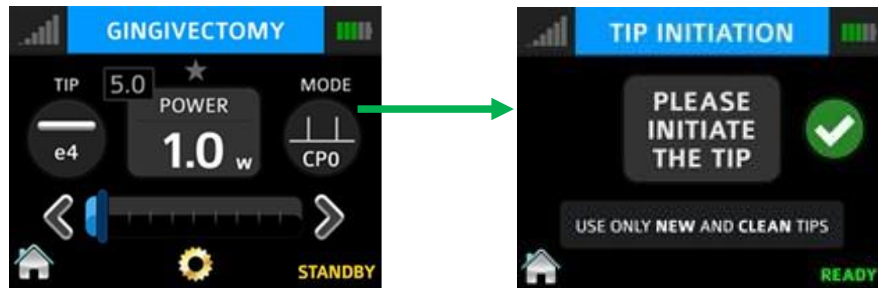

Figure 8.5



CAUTION: If the laser console is in **Ready** mode, the laser will fire if the Footswitch is activated.

PRE-PROGRAMMED SETTINGS FOR DENTAL PROCEDURES

To access the pre-programmed procedure values:

1. Go to the procedures menu by pressing the Soft-tissue icon on the Home screen.
2. Press the button associated with the desired procedure.
3. Press the up and down arrows to scroll for additional procedures.

To store your personal preferred settings for any procedure:

- A. Follow steps 1 and 2 above
- B. Enter the new values
- C. Touch and hold the procedure name for more than 2 seconds; you will hear a beeping sound confirming the settings are saved.



NOTE: The procedure pre-sets installed at the factory are based on clinical recommendations and feedback from experienced laser dentists. 300µm Tips are recommended for removing thin tissue layers. 400µm Tips are recommended for removing fibrous tissue.

Always use clinical judgement when selecting power, pulse, length, and pulse interval parameters to ensure optimal clinical results. **The recommended settings apply only to the 300µm and 400µm tips.** At all times observe the clinical effects on the treatment area and adjust parameters accordingly.

8 Clinical Applications

8.3 TABLE OF PRE-PROGRAMMED SURGICAL SETTINGS

	Preset name	Indications for Use	Mode	Peak power	Avg. Power	Pulse Interval	Pulse Length	Duty Cycle
1	Gingivectomy/ Gingivoplasty	Reduction of gingival hypertrophy, vestibuloplasty	CP0	5.0 W	1.0 W	0.04 ms	0.01 ms	20%
2	Troughing	Tissue retraction for impression, gingival troughing for crown impressions	CP2	2.0 W	1.0 W	1.0 ms	1.0 ms	50%
3	Curettage	Laser soft-tissue curettage	CP1	2.4 W	0.8 W	0.2 ms	0.1 ms	30%
4	Excision	Fibroma removal, excisional and incisional biopsies, gingival incision and excision, operculectomy, oral papillectomies, incision and drainage of abscess	CP1	2.7 W	0.9 W	0.2 ms	0.1ms	30%
5	Frenectomy/ Frenotomy	Frenectomy / Frenotomy	CP1	2.0 W	1.0 W	1.0 ms	1.0 ms	50%
6	Implant Recovery	Implant recovery	CP2	2.4 W	1.2 W	1.0 ms	1.0 ms	50%
7	Perio Pockets	Sulcular debridement (removal of diseased, infected, in aamed and necrosed soft-tissue in the periodontal pocket to improve clinical indices gingival index, gingival bleeding index, probe depth, attachment loss and tooth mobility)	CP2	1.6 W	0.8 W	1.0 ms	1.0 ms	50%
8	Pulpotomy(*)	Pulpotomy, pulpotomy as an adjunct to root canal	CW	0.1 W	0.1 W	N/A	N/A	N/A

(*)Minimum defaults provided for user setting of Endodontic Procedures such as Pulpotomy and Pulpotomy as an adjunct to root canal therapy.

8 Clinical Applications

8.3 TABLE OF PRE-PROGRAMMED SURGICAL SETTINGS (CONTINUED)

	Preset name	Indications for Use	Mode	Peak power	Avg. Power	Pulse Interval	Pulse Length	Duty Cycle
9	Crown Lengthening	Soft-tissue crown lengthening	CP1	2.7 W	0.9 W	0.2 ms	0.1 ms	30%
10	Infected Pockets	Laser removal of diseased, infected, inflamed and necrosed soft-tissue within the periodontal pocket.	CP2	1.6 W	0.8 W	1.0 ms	1.0 ms	50%
11	Endo(*)	Pulpotomy, pulpotomy as an adjunct to root canal	CW	0.1 W	0.1 W	N/A	N/A	N/A
12	Hemostasis	Hemostasis	CW	0.5 W	0.5 W	N/A	N/A	N/A
13	Aphthous Ulcer	Treatment of canker sores, herpetic and aphthous ulcers of the oral mucosa, leukoplakia	CW	0.7 W	0.7 W	N/A	N/A	N/A
14	Exposure of Unerupted Teeth	Exposure of unerupted teeth	CP2	1.8 W	0.9 W	N/A	N/A	N/A
15-17	Custom 1-3	N/A	CW	0.1 W	0.1 W	N/A	N/A	N/A
18-20	Custom 4-6	N/A	CW	0.1 W	0.1 W	N/A	N/A	N/A

(*)Minimum defaults provided for user setting of Endodontic Procedures such as Pulpotomy and Pulpotomy as an adjunct to root canal therapy.

Figure 8.6

8 Clinical Applications

8.4 TEETH WHITENING

PRESET VALUES

- 7W, CW, 30 seconds



NOTE: Settings for the teeth whitening procedure are pre-programmed at the factory and are fixed; these settings cannot be adjusted by the user.

The following items are required to perform teeth whitening with the Epic 10 laser:

- Epic 10 diode laser
- Whitening Handpiece
- Laserwhite™ 20 Whitening Gel Kit

Detailed step-by-step instructions, contraindications, precautions, and warnings for teeth whitening are provided with the Laserwhite™ 20 Whitening Gel Kit. Please read the instructions carefully before proceeding.



Figure 8.7 Laserwhite™ 20 Whitening Gel Kit

8.5 PAIN THERAPY

The Epic 10 diode laser is designed to provide near-infrared laser energy to a tissue surface for the purpose of temporary pain relief when applied with the Deep Tissue Handpiece. The pain therapy procedure elevates tissue temperature for the temporary relief of minor pain, the temporary increase in local blood circulation, and the temporary relaxation of muscle, as stated in the indications for use.

Affected muscles and/or joints have to be exposed to an adequate level of therapeutic energy over a short period of time to provide effective ameliorative effects. Some patients may require more than one laser application or a series of treatments before significant improvement is reported. Repeat the therapy as necessary and monitor the progress of the patient's condition throughout the treatment.

Refer to the Fitzpatrick Skin Type Scale when performing pain therapy procedures. The diode wavelength has increased absorption in melanin in the skin, causing greater heating of the skin surface of patients with a higher melanin concentration (darker skin types). Patients with higher melanin content in their skin may feel more discomfort during treatment, which may be alleviated by moving the Handpiece to defocus the energy, or decreasing the power setting.

PAIN THERAPY PRESET VALUES

The default settings for pain therapy are 2.75W, 10 minutes, with the spot size at 30mm. Power can be adjusted from 2.75W to 4W max, as appropriate, based on the Fitzpatrick Skin Type Scale. Always start at the lowest power setting and increase as necessary.



NOTE: To adjust the power, press the power indicator window in the center of the screen, then use the scroll bar to adjust the power level up or down.

8 Clinical Applications

The Handpiece can be used in a constant location or moved around the treatment area. If holding the Handpiece in a constant location, adjust the settings on the screen to the recommended initial power settings with the spacer set at the 30mm spot size for therapeutic effect. Always monitor patient response; adjust power and/or distance as needed for patient comfort.

Fitzpatrick Skin Type Scale		Maximum Recommended Power / Exposure
TYPE I	Always burns, never tans (pale white; blond or red hair; blue eyes; freckles).	Not recommended for laser therapy
TYPE II	Usually burns, tans minimally (white; fair; blond or red hair; blue, green, or hazel eyes).	3.25W / 10 minutes
TYPE III	Sometimes mild burn, tans uniformly (cream white; fair with any hair or eye color).	4.00W / 10 minutes
TYPE IV	Burns minimally, always tans well (moderate brown).	3.50W / 10 minutes
TYPE V	Very rarely burns, tans very easily (dark brown).	3.25W / 10 minutes
TYPE VI	Never burns, never tans (deeply pigmented dark brown to darkest brown).	2.75W / 10 minutes

Figure 8.8

PAIN THERAPY – ADVERSE EFFECTS

Some reddening of the skin at the treatment site is normal due to increased circulation; however, in very rare cases burning or blistering of the skin may occur. Immediately stop treatment, rinse the area with cool water or place a cold pack to the affected area for at least 5 minutes, then apply a burn ointment or spray. **DO NOT USE ICE.**

Patients should be monitored for discomfort and visual skin changes. Redness has been associated with increased temperature at the site of application and increased absorption properties of the skin. If discomfort or redness of the skin occurs at any time during the treatment, you have the following options:

- Move the Handpiece relative to the affected anatomy
- Defocus the energy by moving the Handpiece further away from the skin
- Decrease the power setting
- Stop treatment

8 Clinical Applications

Patients suffering from general neurovascular conditions, such as neurodegeneration associated with Type II diabetes, may have reduced sensitivity to pain affecting their response to discomfort during treatment. Refer to Section "Contraindications, Warnings, and Precautions" for additional information.

PAIN THERAPY – WARNINGS AND PRECAUTIONS

- Scar tissue has been associated with poor circulation and reduced cooling through heat transport by blood; power settings may have to be reduced to avoid overheating
- Patients with tender or sensitive skin may be hypersensitive to heat; reduce power as necessary to ensure comfort during treatment
- Patients with swelling and/or inflammation may be sensitive to heat; reduce power as necessary to ensure comfort during treatment
- **Do not** treat open wounds
- Muscle tissue closer to the skin surface may experience a higher absorption of heat; carefully monitor skin temperature and reduce power as necessary
- Excessive fatty tissue is known to transmit heat without much attenuation; reduce power
- Different implant materials will respond differently to laser energy and heat; be aware of any implants and their location; avoid direct exposure to laser energy or heat at the site of the implant
- **Avoid** treatment of sites that have tattoos
- **Do not** apply ointment, creams, lotions or heating lotion patches at, or in close proximity to, the treatment area
- **Do not** apply therapies prior to treatment that could change body temperature, such as ultrasound, ice/heat pack, electrical stimulation, or heating patches
- **Do not** apply treatment over articles of clothing
- **Do not** apply any numbing agents to the affected area as they could reduce the patient's pain sensitivity and response to any treatment discomfort

8 Clinical Applications

RECOMMENDED USE

There are four main variables that impact the safety and effectiveness of pain therapy procedures:

- Power output
- Distance from the skin surface
- Range of movement of the Handpiece
- Patient skin type

Safety and efficacy are described by elevating the skin temperature in the treatment area utilizing the recommended settings (Figure 8.8). Use personal clinical judgment with consideration of the Fitzpatrick Skin Type Scale when setting the procedure parameters; monitor the patient and adjust the settings as necessary for effectiveness and comfort.



NOTE: To avoid potential patient discomfort and/or skin damage, it is advisable to use a test spot prior to the initial treatment to assess the suitability of the selected settings for the individual patient.

9 Maintenance

9.1 DAILY MAINTENANCE

Disposable screen protectors are supplied with the Epic 10 laser system. Apply these peel-off clear covers to the console screen to protect it from water and debris, and discard after use. Use disinfectant to wipe down the front panel and Handpiece Holder of the Epic 10 system after each procedure. **Do not use bleach or abrasive cleansers.**

9.2 CLEANING AND STERILIZATION PROCEDURES

The contamination control suggested for the Epic 10 Surgical Handpiece and Tips is the steam sterilization method. However, before sterilization, the Surgical Handpiece should be MANUALLY cleaned per the procedure noted below.



CAUTION: Handpieces and laser Tips are not sterile when sold and must be sterilized prior to initial use, and Handpieces must be cleaned and sterilized between patients. **Tips are single-use only** and must be discarded after single use in a biohazard medical waste sharps container. **Cleaning must be performed within a maximum of 1 hour after the procedure and prior to sterilization.**



CAUTION: The Fiber Optic Cable cannot be autoclaved; doing so will make it unusable. However the Fiber Optic Cable must be disinfected between patients by following the procedure outlined in Step 3 of this section.

STEP 1 - CLEANING PROCESS – SURGICAL HANDPIECE

The cleaning process is intended to remove blood, protein and other potential contaminants, as well as to reduce the quantity of particles, microorganisms and pathogens present from the Handpiece surface and crevices. Cleaning should be performed prior to sterilization and must be conducted only by qualified personnel trained in the process who know how to handle the laser Handpiece.

Wear protective latex gloves when handling the contaminated delivery system.

1. After use, carefully remove the Tip from the Handpiece and discard in a biohazard medical waste sharps container.
2. Carefully remove the Handpiece from the Fiber Optic Cable.
3. Prepare any commercially available surgical instrument detergent/enzymatic cleaning solution with a pH of 7.0, such as Enzol® or similar enzymatic presoak and cleaner, per the manufacturer's instructions. (Follow the manufacturer's instructions for disposal of used solution.)
4. Rinse the Handpiece under running lukewarm tap water (22 – 43°C) for a **minimum of 10 seconds** to remove gross soil.
5. Wrap the Handpiece in a piece of gauze that has been soaked in the cleaning solution; leave it wrapped in the gauze for a **minimum of 10 minutes**.
6. Unwrap the Handpiece from the gauze and use a soft-bristled brush dipped in the cleaning solution to gently scrub it for **at least 15 seconds**.

9 Maintenance

7. Rinse the Handpiece under running lukewarm tap water (22-43°C) for a **minimum of 10 seconds** and then dry with a lint-free cloth.
8. Visually inspect the Handpiece for any residual soil. If necessary, repeat steps 5 - 7 until **all** residual soil is removed.

STEP 2 - STERILIZATION PROCESS – SURGICAL HANDPIECE

The steam sterilization process is intended to destroy infectious microorganisms and pathogens.



NOTE: Always perform the procedure immediately after cleaning and prior to use; **only** use FDA-cleared (USA) or CE-marked (Europe) sterilization accessories, i.e., sterilization pouch and autoclave tray. The product packaging is **NOT** suitable for steam sterilization

1. Place the Handpiece and fiber Tips in separate single-wrap, self-seal autoclave pouches.
2. Place on an autoclave tray; do not stack other instruments on top of the pouches.
3. Place the tray inside the autoclave chamber and set the appropriate cycle as recommended in Figure 9.1.

Type of Sterilizer	Temperature	Minimum Time	Drying Time
Gravity Displacement	121°C (250°F)	30 minutes	15 – 30 minutes
	132°C (270°F)	15 minutes	
Dynamic-Air-Removal (Pre-Vacuum)	132°C (270°F)	4 minutes	20 – 30 minutes
Dynamic-Air-Removal (Pre-Vacuum)	134°C (273°F)	3 minutes	20 minutes

Figure 9.1

Once the cycle is completed, remove the tray and let each sterilized item cool and dry.

The Handpiece and Tips must remain in the sterilization pouches until used in order to maintain sterility.

To re-connect the Handpiece to the Fiber Optic Cable, push the Handpiece onto the fiber shaft without twisting until it clicks into place and is secured, as described in Section 7.3.

9 Maintenance

STEP 3 – DISINFECTING THE FIBER OPTIC CABLE

Always disinfect the fiber between patients by wiping it completely with an appropriate disinfecting solution such as Cavicide™ or a similar quaternary ammonium compound product (containing 20% alcohol or less), and follow the manufacturer's instructions. **DO NOT AUTOCLAVE.**

DISINFECTING THE WHITENING HANDPIECE

The Whitening Handpiece is sold with non-sterile disposable protective shields.

The Handpiece and protective shield **cannot be autoclaved**. The clear protective shields are intended for one-time use only and should never be reused to prevent cross-contamination.

- To disinfect the Whitening Handpiece, wipe down the Handpiece with gauze and isopropyl alcohol.
- Always wipe the disposable shield with alcohol prior to use. Discard after single use.

DISINFECTING THE DEEP TISSUE HANDPIECE

The Deep Tissue Handpiece is sold with non-sterile, disposable protective shields.

The Handpiece and protective shields **cannot be autoclaved**. The clear protective shields are intended for single use only and should never be reused to prevent cross-contamination.

- To disinfect the Deep Tissue Handpiece, wipe the entire outer surface of the Handpiece with cotton gauze and isopropyl alcohol or a mild chemical disinfectant.
- Always wipe the disposable shield with alcohol prior to use. Discard after single use.

9 Maintenance

9.3 FIBER OPTIC CABLE LENS INSPECTION AND CLEANING

LENS INSPECTION PROCEDURE

The lens is at the distal end of the Fiber Optic Cable (Figure 9.2); this is where debris may accumulate over time with use. To inspect the lens, take the following steps:



CAUTION: DO NOT inspect the lens while the laser system is powered on; the aiming beam or laser beam can permanently impair vision if aimed at the eye.



CAUTION: Never reuse single-use Tips as this will damage the Fiber Optic Cable.

1. Remove the Handpiece from the fiber shaft.
2. Inspect the distal end of the fiber using a magnifier or loupes with at least 10X magnification (Figure 9.3).
3. Inspect the lens.



Figure 9.2

CLEANING THE LENS

If debris or dark spots are observed on the lens, clean the window using the procedure outlined below.

1. Always use a new, unused Microbrush (provided) to clean the lens (Figure 9.4).
2. Dip the Microbrush in isopropyl alcohol.
3. Gently rub the lens surface to remove debris or dark spots (Figure 9.5).
4. Repeat as needed using a new Microbrush each time until no residue appears on the swab.

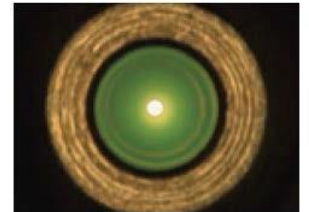

Figure 9.3



Figure 9.4



CAUTION: If blemishes appear below or inside the lens, contact BIOLASE or your authorized service representative to order a replacement lens.

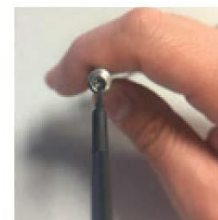

Figure 9.5

9 Maintenance

9.4 INSTALLING/REPLACING THE CONSOLE BATTERY PACK

1. To install or replace the battery pack, remove the battery cover on the underside of the console using the Phillips screwdriver included with the laser system.
2. To remove the battery, grip the battery at the top and pull the cable away from the connector. Do not tug or wrench the cable from the connector.
3. To install the battery, insert the connector wire from the battery to the unit, making sure the red wire is on the left, and gently place the battery into the compartment.
4. Replace the battery cover on the bottom of the unit, using the Phillips screwdriver provided.
5. Connect the power cord of the DC power supply module to the unit and plug into a wall outlet. Before first use, it is recommended to fully charge the battery for at least three 3 hours. Once the battery is charged, unplug the power cord from the wall outlet and the console. The unit will run on battery power alone.
6. Dispose of the used Lithium Ion battery as regulated. Do not discard in a trash bin.

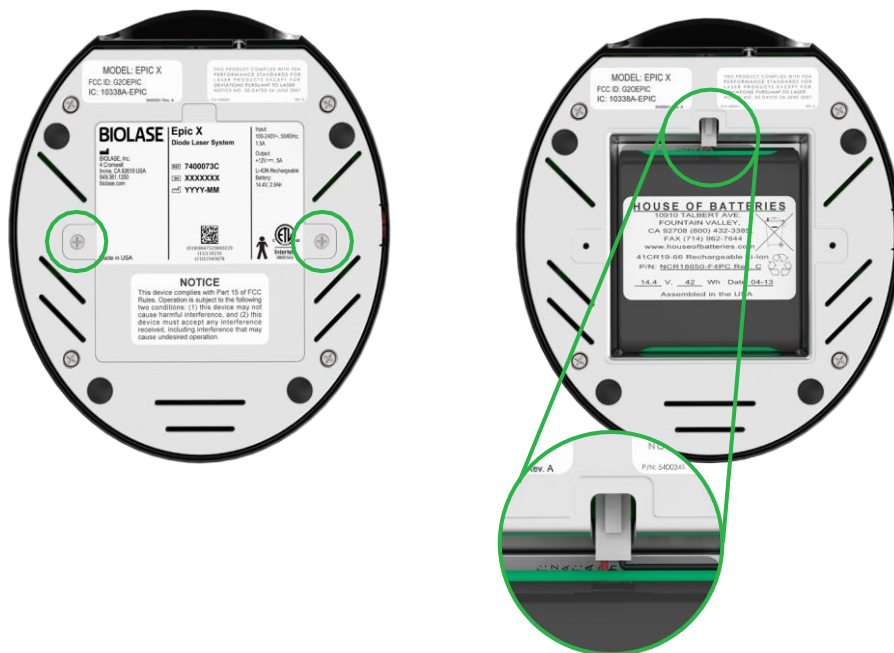

Figure 9.6



NOTE: Only use the battery pack supplied by BIOLASE. The battery pack is a separate accessory (BIOLASE P/N 4400268).

9 Maintenance

9.5 CHANGING THE WIRELESS FOOTSWITCH BATTERIES

The wireless Footswitch is powered by two AAA batteries. When the batteries are low, a warning message will appear on the display screen indicating that the batteries need to be replaced. To replace the batteries, remove the 3 screws on the underside of the Footswitch to remove the battery cover (Figure 9.7); take out the old batteries and install the new ones, replacing the cover when done. Discard the used batteries as regulated; do not throw them in a trash bin.

Do not press/push/touch the pairing button (Figure 9.8) while changing the batteries, as this will disrupt the pairing of the laser console and Footswitch.

Replacing the batteries may disrupt the pairing of the laser console and Footswitch. If you find the wireless communication has been interrupted, reestablish pairing by following the instructions provided in Section 7.



Figure 9.7 battery cover screws

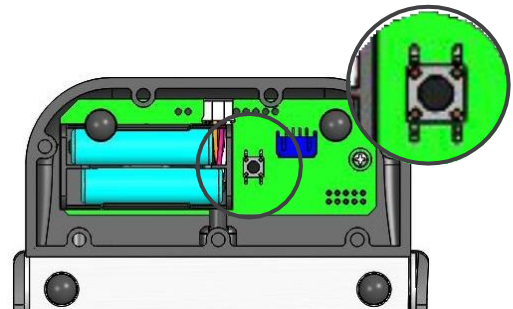

Figure 9.8 pairing button (internal view)



NOTE: To ensure the longevity of the battery power, only BIOLASE-supplied batteries are recommended as replacements (BIOLASE p/n 2400203); these are industrial-grade batteries which under normal use have a longer life than conventional AAA batteries.

9 Maintenance

9.6 TRANSPORTATION

The Epic 10 is susceptible to damage if not handled properly. The unit should ALWAYS be handled carefully and never banged, jarred, jolted, dropped, or knocked.

Do not transport the unit unless it is completely packaged inside its shipping box. If you have any questions regarding transportation please call BIOLASE Service at **1-800-321-6717**.

9.7 STORAGE

The Epic 10 should be stored in a cool, dry place when not in use under the following environmental conditions:

- Storage temperature: 15°C-35°C (59°F-95°F)
- Relative humidity: 10%-90%, non-condensing

Cover the unit when not in use for extended periods of time. Store the system in a place where it will not be accidentally bumped or banged.

The Epic 10 is shipped inside a custom shipping box. Please save and store the box in a cool, dry place for use when transporting the laser, or for long-term storage.



CAUTION: Make sure the distal end of the fiber shaft is protected from dirt by removing the Handpiece and installing the red protective cap over the end of the fiber.

Remove the batteries from the Footswitch if the Epic 10 is not likely to be used for some time.



NOTE: At end-of-life, final disposition of the laser must be done as required by local waste electrical and electronic equipment (WEEE) laws.

10 Calibration

Calibration is recommended every twenty-four (24) months in order to maintain the required accuracy of output power versus displayed power and can be performed at a certified depot repair facility. Call BIOLASE Service at **1-800-321-6717** or your Authorized Service Representative to schedule an appointment.

11 Software Specification

BIOLASE respects the intellectual property of others, and we ask our users to do the same. Epic 10 software is protected by copyright and other intellectual property laws. This product contains proprietary, copyrighted software developed by BIOLASE, Inc. All rights reserved in the USA and other countries

12 Troubleshooting

TROUBLESHOOTING

Should any of the on-screen messages listed in Figure 12.1 and Figure 12.2 appear, follow the troubleshooting instructions for the specific message as noted below.



NOTE: For any on-screen message not listed in Figure 12.1, re-power the laser console; if the message does not clear, call BIOLASE Service at **1-800-321-6717** or your Authorized Service Representative.

Screen	Message	Reason	Fix
Warning 1	Temperature high	System is hot	Allow 5-10 minutes for laser to cool down
Warning 2	Battery is low	Battery is low	Plug in DC supply
Warning 3	Battery is not connected	Battery is not connected	Plug in the battery
Warning 4	Footswitch battery is low	Battery on the Footswitch is low	Replace Footswitch battery
Warning 5	Footswitch	Footswitch held	Release Footswitch
Alert	Wireless not paired	No wireless connection	Re-establish pairing (see sec 4)
Alert 2	System must be in Ready mode to lase	System is not in Ready mode	Press the control button in any procedure screen

Figure 12.1

12 Troubleshooting

Screen	Message	Reason	Fix
Error 1	Thermistor open	Thermistor open	Call BIOLASE Service
Error 2	Thermistor shorted	Thermistor shorted	Call BIOLASE Service
Error 3	Shutdown temperature	System too hot	Allow 5-10 minutes for laser to cool down
Error 4	Laser current high/low	Output is out of specs	Call BIOLASE Service
Error 5	Footswitch shorted	Footswitch is partially pressed or damaged	Press/release Footswitch or call BIOLASE service
Error 6	ON/OFF button stuck	Key stuck	Press front key
Error 7	Flash corrupted	Memory corrupted	Call BIOLASE Service
Error 8	No Fiber	Fiber not inserted	Plug in Fiber Optic Cable
Error 9	Lost Footswitch communication	Wireless interference	Reposition console/Footswitch to improve communication
Error 10	Emergency switch	E-switch pressed	Press E-switch again
Error 11	Remote interlock	Remote interlock open	Check remote interlock closed
Error 12	Battery critically low	Battery is critically low	Plug in DC supply
Error 13	Internal error	Internal error occurred	Restart unit
Error 14	Footswitch battery	Footswitch battery critically low	Replace Footswitch battery





Figure 12.2

Appendix A Tip Guide



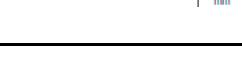
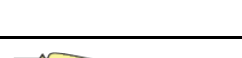
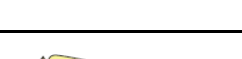
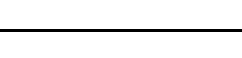

NOTE: All BIOLASE tips for diode lasers are sold non-sterile and are for single-use only. See Section 9 in this User Manual for cleaning and sterilization instructions.

NON-INITIATED

Tip	Name	Diameter	Length (mm)	Application	Part Number
	E4-4	400µm	4	Surgical	7400016
	E4-7	400µm	7	Perio	7410003/ 7400019
	E4-9	400µm	9	Perio	7400019
	E3-4	300µm	4	Surgical	7400017
	E3-7	300µm	7	Perio	7410002/ 7400020
	E3-9	300µm	9	Perio	7400020
	E2-14	200µm	14	Endo	7400021
	E2-20	200µm	20	Endo	7400015

PRE-INITIATED

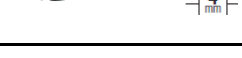
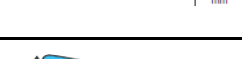
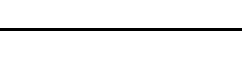





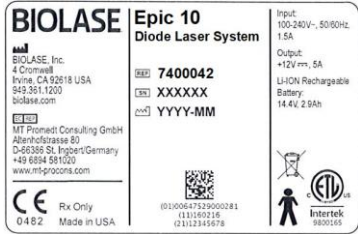

Tip	Name	Diameter	Length (mm)	Application	Part Number
	Pi4-4	400µm	4	Surgical	7400067
	Pi4-7	400µm	7	Perio	7400068
	Pi4-9	400µm	9	Perio	7400069
	Pi3-4	300µm	4	Surgical	7400071
	Pi3-7	300µm	7	Perio	7400064
	Pi3-9	300µm	9	Perio	7400065

Appendix B Accessories

APPENDIX B – ACCESSORIES

PART NO.	DESCRIPTION
6400105	Surgical Handpiece (1-pack)
2400277	Laser Safety Goggles
6400058	Remote Interlock Plug
2400075	DC Power Supply Module
2400043	Power Cord (U.S.)
2400055	Power Cord (International)
6400541	Wireless Footswitch
6400107	Tip Initiation Kit
7400022	Whitening Handpiece
6400180	Whitening Handpiece Disposable Shields (30-pack)
7400030	Laserwhite 20 Whitening Gel Kit (5-pack)
6400311	Deep Tissue Handpiece
6400310	Deep Tissue Handpiece Disposable Shields (qty. 20)
6400465	Peel-off Clear Screen Protectors (qty. 30)
6400457	Lithium-Ion Battery Pack for Console
6400463	Battery Pack (2 x AAA)
6400437	Fiber Optic Cable
5400386	Laser Warning Sign

Appendix C Labeling

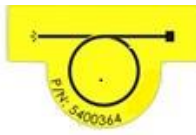
<p>PRODUCT IDENTIFICATION LABEL: LOCATION: Bottom of laser console</p>	 <p>BIOLASE Epic 10 Diode Laser System</p> <p>Input: 100-240V~, 50/60Hz, 1.5A Output: +12V rms, 5A Li-ION Rechargeable Battery: 14.4V, 2.9Ah</p> <p>7400042 XXXXXX YYYY-MM</p> <p>MT Promedl Consulting GmbH Albenhofstrasse 63 D-66386 St. Ingbert/Germany +49 6894 981020 www.mtgroupusa.com</p> <p>CE Rx Only 0482 Made in USA</p> <p>Intertek 9800165</p>
<p>MANUFACTURER</p>	
<p>CATALOG/PART NUMBER</p>	
<p>PRODUCT SERIAL NUMBER</p>	
<p>DATE OF MANUFACTURE</p>	
<p>LASER WARNING: Indicates the system contains a laser</p> <p>LOCATION: Back of Laser Console</p>	
<p>TYPE BF APPLIED PART: The applied part is not conductive to the patient</p>	
<p>EMERGENCY LASER STOP SWITCH: The switch used in emergencies to stop laser output</p> <p>LOCATION: Left side of laser console</p>	
<p>FIBER WARNING: Indicates the system contains a laser</p> <p>LOCATION: Back of laser console</p>	

Appendix C Labeling

CERTIFICATION:

This device complies with FDA laser standards

Complies with FDA performance standards for laser products except for conformance with IEC 60825-1 Ed. 3 and IEC 60601-2-22 Ed. 3.1, as described in Laser Notice 56, dated May 8, 2019.

5400341

Rev. C

LOCATION:

Bottom of laser console

WARNING LABEL:

Indicates there is the risk of possible exposure to both infrared and visible laser radiation



LOCATION:

Back of laser console

FCC AND IC LABEL:

Federal Communication Commission and Industry Canada registration numbers

MODEL: EPIC 10
FCC ID: G2OEPIC-1
IC: 10338A-EPIC

5400540 Rev. A

LOCATION:

Bottom of laser console

REFER TO USER MANUAL



FCC COMPLIANCE NOTICE:

The Footswitch and laser console comply with Part 15 of FCC Rules regarding unlicensed transmissions

NOTICE
This device complies with Part 15 of FCC Rules. Operation is subject to the following two conditions: (1) this device may not cause harmful interference, and (2) this device must accept any interference received, including interference that may cause undesired operation.

LOCATION:

Bottom of Footswitch

INGRESS PROTECTION CODE:



The Footswitch is water-resistant, protected from splashes of water

IPX6

SINGLE USE ONLY – DO NOT REUSE

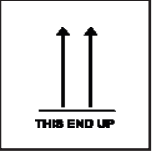

Appendix C Labeling

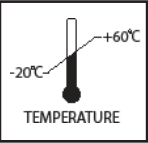
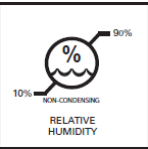
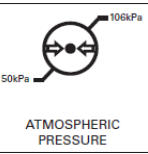
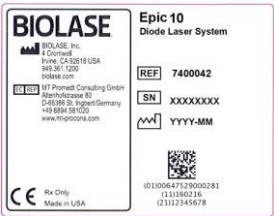
<p>WEEE (WASTE ELECTRICAL AND ELECTRONIC): Recycle lithium ion battery as regulated. Do not throw in trash bin.</p>	
<p>THIS END UP LOCATION: Outer carton (shipping box)</p>	
<p>FRAGILE: HANDLE WITH CARE LOCATION: Outer carton (shipping box)</p>	
<p>KEEP DRY LOCATION: Outer carton (shipping box)</p>	
<p>TRANSPORTATION TEMPERATURE LIMITATIONS LOCATION: Outer carton (shipping box)</p>	
<p>HUMIDITY LIMITATIONS LOCATION: Outer carton (shipping box)</p>	
<p>ATMOSPHERIC PRESSURE LIMITATIONS LOCATION: Outer carton (shipping box)</p>	
<p>SYSTEM SHIPPING LABEL LOCATION: Outer carton (shipping box)</p>	

Appendix C Labeling

LASER WARNING SIGN

Included in the Welcome Kit; must be placed **outside of the operatory** whenever the laser system is in use.



DC POWER, USB, REMOTE INTERLOCK LABEL:

Identifies input ports

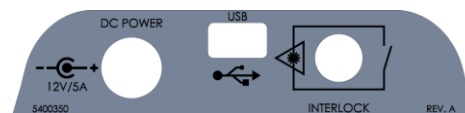

POWER INPUT RATING:

12 Volts Direct Current, 5 amps



MINI USB INPUT:

For external programming



REMOTE INTERLOCK:

Input for Remote Interlock Connector



Appendix D Safety-Lithium-Ion Battery Packs

WHEN USING THE BATTERY:

WARNING:

1. Misusing the battery may cause the battery to get hot, rupture, or ignite and cause serious injury. Be sure to follow the safety rules listed below:
 - Do not place the battery in fire or heat the battery.
 - Do not install the battery backwards so that the polarity is reversed.
 - Do not connect the positive terminal and the negative terminal of the battery to each other with any metal object (such as a wire).
 - Do not carry or store the batteries together with necklaces, hairpins, or other metal objects.
 - Do not pierce the battery with nails, strike the battery with a hammer, step on the battery, or otherwise subject it to strong impacts or shocks.
 - Do not solder directly onto the battery.
 - Do not expose the battery to water or salt water, or allow the battery to get wet.
2. Do not disassemble or modify the battery. The battery contains safety and protection devices which, if damaged, may cause the battery to generate heat, rupture, or ignite.
3. Do not place the battery on or near fires, stoves, or other high-temperature locations. Do not place the battery in direct sunshine or use or store the battery inside cars in hot weather. Doing so may cause the battery to generate heat, rupture, or ignite. Using the battery in this manner may also result in a loss of performance and a shortened life expectancy.

CAUTION:

1. If the device is to be used by small children, the caregiver should explain the contents of the user's manual to the children. The caregiver should provide adequate supervision to ensure that the device is being used as explained in the user's manual.
2. When the battery is worn out, insulate the terminals with adhesive tape or similar materials before disposal.
3. Immediately discontinue use of the battery if, while using, charging, or storing the battery, the battery emits an unusual smell, feels hot, changes color, changes shape, or appears abnormal in any other way. Contact your sales location or BIOLASE if any of these problems are observed.
4. Do not place the batteries in microwave ovens, high-pressure containers, or on induction cookware.
5. In the event that the battery leaks and the fluid gets into one's eye(s), do not rub the eye(s). Rinse well with water and immediately seek medical care. If left untreated, the battery fluid could cause damage to the eye.

Appendix D Safety-Lithium-Ion Battery Packs

WHEN CHARGING THE BATTERY:

WARNING:

1. Be sure to follow the rules listed below while charging the battery. Failure to do so may cause the battery to become hot, rupture, or ignite and cause serious injury.
 - When charging the battery, either use a specified battery charger or otherwise ensure that the battery charging conditions specified are met.
 - Do not attach the batteries to a power supply plug or directly to a car's cigarette lighter.
 - Do not place the batteries in or near fire, or into direct sunlight. When the battery becomes hot, the built-in safety equipment is activated, preventing the battery from charging further, and heating the battery can destroy the safety equipment and can cause additional heating, breaking, or ignition of the battery.
2. Do not continue charging the battery if it does not recharge within the specified charging time. Doing so may cause the battery to become hot, rupture, or ignite.

CAUTION:

- The temperature range over which the battery can be charged is 0°C to 45°C. Charging the battery at temperatures outside of this range may cause the battery to become hot or to break. Charging the battery outside of this temperature range may also harm the performance of the battery or reduce the battery's life expectancy

WHEN DISCHARGING THE BATTERY:

WARNING:

- Do not discharge the battery using any device except for the specified device. When the battery is used in devices aside from the specified device it may damage the performance of the battery or reduce its life expectancy, and if the device causes an abnormal current to flow, it may cause the battery to become hot, rupture, or ignite and cause serious injury.

CAUTION:

- The temperature range over which the battery can be discharged is -20°C to 60°C. Use of the battery outside of this temperature range may damage the performance of the battery or may reduce its life expectancy

Appendix E Electromagnetic Compatibility



CAUTION: Medical electrical equipment needs special precautions regarding electromagnetic compatibility (EMC) and needs to be installed and put into service according to the EMC information provided in the following tables.

Portable and mobile radio frequency (RF) communications equipment can affect medical electrical equipment.

Accessories: Medical grade power cord, maximum length 3ft (1 meter), BIOLASE p/n 2400043
 DC Power Supply Module, BIOLASE p/n 2400075
 Wireless Footswitch, BIOLASE p/n 6400541



WARNING: The use of accessories other than those supplied or sold by BIOLASE, Inc. as replacement parts for internal or external components may result in increased EMISSIONS or decreased IMMUNITY of the Epic 10 diode laser system.

GUIDANCE AND MANUFACTURER'S DECLARATION – ELECTROMAGNETIC EMISSIONS		
The Epic 10 is intended for use in the electromagnetic environment specified below. The customer or the user of the Epic 10 should assure it is used in such an environment.		
Emissions Test	Compliance	Electromagnetic environment - guidance
RF radiated emissions CISPR 11	Group 1, Class A/B	The Epic 10 is suitable for use in all establishments other than domestic and those directly connected to the public low-voltage power supply network that supplies buildings used for domestic purposes.
RF conducted emissions CISPR 11	Group 1, Class A/B	
Harmonic emissions IEC 61000-3-2	Class A	
Voltage fluctuations/flicker emissions IEC 61000-3-3	Class A	

Appendix E Electromagnetic Compatibility

GUIDANCE AND MANUFACTURER'S DECLARATION – ELECTROMAGNETIC IMMUNITY			
The Epic 10 is intended for use in the electromagnetic environment specified below. The customer or the user of the Epic 10 should assure that it is used in such an environment.			
Immunity test	IEC 60601 test level	Continuous level	Electromagnetic environment - guidance
Electrostatic discharge (ESD) IEC 61000-4-2	$\pm 2, \pm 4, \pm 8$ kV contact $\pm 2, \pm 4, \pm 8, \pm 15$ kV air	$\pm 2, \pm 4, \pm 8$ kV contact $\pm 2, \pm 4, \pm 8, \pm 15$ kV air	Floors should be wood, concrete or ceramic tile. If floors are covered with synthetic material, relative humidity should be at least 50%.
Electrical fast transient/burst IEC61000-4-4	100 kHz repetition ± 2 kV for power supply lines 100 kHz repetition ± 1 kV for input/output lines	100 kHz repetition ± 2 kV for power supply lines N/A	Main power quality should be that of a typical commercial or hospital environment. Input/output that does not apply because the footswitch cable length is less than 3 meters.
Surge IEC 61000-4-5	± 1 kV differential mode ± 2 kV common mode	± 1 kV differential mode ± 2 kV common mode	Mains power quality should be that of a typical commercial or hospital environment.
Voltage dips, short interruptions and voltage variations on power supply input lines. IEC 61000-4-11	0% U_T for 0.5 cycle 0% U_T for 1.0 cycle 70% U_T for 25 cycles (50 Hz/60 Hz) 0% U_T for 250 sec/300 cycles (50 Hz/60 Hz)	0% U_T for 0.5 cycle 0% U_T for 1.0 cycle 70% U_T for 25 cycles (50 Hz/60 Hz) 0% U_T for 250 sec/300 cycles (50 Hz/60 Hz)	Mains power quality should be that of a typical commercial or hospital environment. If the user of the model Epic 10 requires continued operation during power mains interruptions, it is recommended that the model Epic 10 be powered from an uninterrupted power supply.
Power frequency (50-60 Hz) magnetic field IEC 61000-4-8	30 A/m	30 A/m	Power frequency magnetic fields should be at levels characteristic of a typical location in a typical commercial or hospital environment.

NOTE: U_T is the A.C. mains voltage prior to applications of the test level.

Appendix E Electromagnetic Compatibility

GUIDANCE AND MANUFACTURER'S DECLARATION – ELECTROMAGNETIC IMMUNITY (Continued)

The Epic 10 is intended for use in the electromagnetic environment specified below. The customer or the user of the Epic 10 should assure that it is used in such an environment.

Immunity test	IEC 60601 test level	Continuous level	Electromagnetic environment - guidance
Conducted RF IEC 61000-4-6	3 Vrms 150 kHz to 80 GHz	3 Vrms 150 kHz to 80 GHz	Portable and mobile RF communications equipment should be used no closer to any part of the model Epic 10, including cables, than the recommended separation distance calculated from the equation applicable to the frequency of the transmitter. Recommended separation distance $d = 1.2\sqrt{P}$ $d = 1.2\sqrt{P}$ 80 MHz to 800 MHz $d = 2.3\sqrt{P}$ 800MHz to 2.5GHZ Where P is the maximum output power rating of the transmitter in watts (W) according to the transmitter manufacturer and d is the recommended separation distance in meters (m). Field strengths from fixed RF transmitters, as determined by an electromagnetic site survey, ^a should be less than the compliance level in each frequency range. ^b Interference may occur in the vicinity of equipment marked with the following symbol: 
Radiated RF IEC61000-4-3	9 V/m to 28 V/m 385 to 5785 MHz	6Vrms At the standard specified ISM band	

NOTE 1 - At 80 MHz and 800 MHz, the higher frequency range applies.

NOTE 2 – These guidelines may not apply in all situations. Electromagnetic propagation is affected by absorption and reflection from structures, objects, and people.

Appendix E Electromagnetic Compatibility

RECOMMENDED SEPARATION DISTANCE BETWEEN PORTABLE AND MOBILE RF COMMUNICATIONS EQUIPMENT AND THE EPIC 10

The Epic 10 is intended for use in an electromagnetic environment in which radiated RF disturbances are controlled. The customer or the user of the Epic 10 can help prevent electromagnetic interferences by maintaining a minimum distance between portable and mobile RF communications equipment (transmitters) and the Epic 10 as recommended below, according to the maximum output power of the communications equipment.

Rated maximum output power of transmitter W	Separation distance according to frequency of transmitter (m)		
	150kHz to 80Mhz $d = 1.2\sqrt{P}$	80 MHz to 800 MHz $d = 1.2\sqrt{P}$	800 MHz to 2.5 GHz $d = 2.3\sqrt{P}$
0.01	0.12	0.12	0.23
0.1	0.38	0.38	0.73
1	1.2	1.2	2.3
10	3.8	3.8	7.3
100	12	12	23

For transmitters rated at a maximum output power not listed above, the recommended separation distance d in meters (m) can be estimated using the equation applicable to the frequency of the transmitter, where P is the maximum output power rating of the transmitter in watts (W) according to the transmitter manufacturer.

NOTE 1 – At 80 MHz and 800 MHz, the separation distance for the higher frequency range applies.

NOTE 2 – These guidelines may not apply in all situations. Electromagnetic propagation is affected by absorption and reflection from structures, objects, and people.

Appendix F Wireless Equipment Compliance Statement

This statement applies only to the wireless portion of the device:

This equipment has been tested and found to comply with the limits for a Class B digital device, pursuant to part 15 of the FCC Rules. These limits are designed to provide reasonable protection against harmful interference in a residential installation. This equipment generates, uses, and can radiate radio frequency energy and, if not installed and used in accordance with the instructions, may cause harmful interference to radio communications. However, there is no guarantee that interference will not occur in a particular installation. If this equipment does cause harmful interference to radio or television reception, which can be determined by turning the equipment off and on, the user is encouraged to try to correct the interference by one or more of the following measures:

- Reorient or relocate the receiving antenna
- Increase the separation between the equipment and receiver
- Connect the equipment into an outlet on a circuit different from that to which the receiver is connected
- Consult the dealer or an experienced radio/TV technician for help



Conforms to:
AAMI
ES60601-1
IEC60601-1
IEC60601-2-22
IEC62366
IEC80601-2-60
IEC60825-1
Certified to:
CSA C22.2
No. 60601-1

BIOLASE

biolase.com



BIOLASE, INC.

27042 Towne Centre Drive, Suite 270
Foothill Ranch, CA 92610-2811 USA

Toll-Free: (833) BIOLASE
Telephone: (949) 361-1200
Fax: (949) 273-6687
Service: (800) 321-6717



EU REGULATORY

MT Promedt Consulting GmbH
Altenhofstrasse 80
D-66386 St. Ingbert/Germany
+49 6894 581020
www.mt-procons.com

MADE IN THE USA

Copyright ©2021 BIOLASE, Inc. All rights reserved.

iPlus™ software copyright ©2016 BIOLASE, Inc.

Epic, iLase, ezLase, ezTip, LaserWhite, Deep Tissue Handpiece, ComfortPulse, Waterlase, and Waterlase iPlus are either trademarks or registered trademarks of BIOLASE, Incorporated in the United States and/or other countries. All other trademarks are property of their registered owners. Subject to change without notice.